

# DIGI-TAILS

DIGITAL TAILLIGHTS  
Sequential LED Tail Light Kit Installation Guide

## 1971-73 DODGE DART PN 1200471

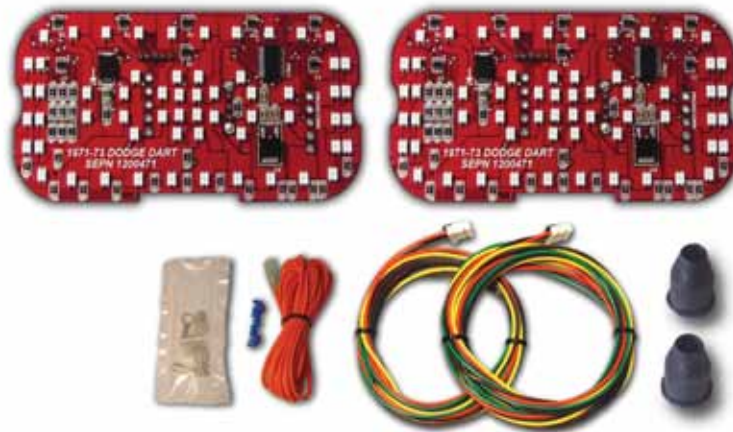

Please refer to Invoice for full warranty information  
DIGI-TAILS is not a licensed MOPAR product

## Note

The LED boards are shipped with the slide switch set to Sequential mode. It is recommended that slide switches on all the LED boards be set to the same setting (either standard or sequential). Please follow all local laws concerning exterior lighting.

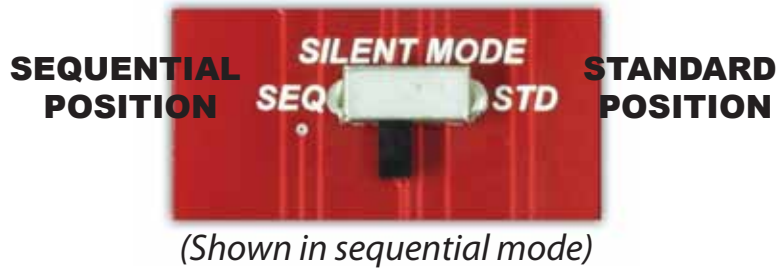

Remove the negative terminal from the battery to cut off all power in your car. Press on the brake pedal to verify that your brake lights are not lighting up.

As a safety precaution, remove the bulbs out of the sockets and put them away since they will no longer be needed. Remove the tail light lens. Removal of the tail light housing assembly from the car may be required.

Cut and remove the original wires from the housing. Pull them all the way back out through the body grommet into the trunk area.



Feed the new harness through the housing. To protect the wiring from the exterior elements, slide on the included rubber boot and shrink tube sleeve over the new wires and seal them shut. Once the socket end and wires are weather tight feed the bare ends into the car through the body grommet.



## WIRE SPLICE INSTALLATION

Pick a point in the rear body harness between the driver's side quarter panel and the driver's side tail light housing assembly and remove the cloth tape to expose the tail light wires.

The LED harness **DARK GREEN** wires splice in with the original **DARK GREEN** wires.

The LED harness **BROWN** wires splice in with the original **BROWN** wires.

The light sockets on the car harness are no longer needed.

The LED harness **YELLOW** wires splice in with the original **BLACK** running light wires. The ends going to the side marker light sockets must be included in the splice for the side markers to remain functional.

Take the ground wires and connect them all together. Bolt them to the trunk latch support along with the original rear body harness ground.

An **ORANGE** power wire is supplied along with a T-Tap. The orange power wire must be supplied with a constant 12 volt battery supply for the LED circuitry to operate properly. The T-Tap connector is used to splice to the constant power source, such as the dome light or trunk light wire.

Splice the T-Tap connector into the constant power wire, then plug the orange wire into the T-Tap. The other end of the orange wire is spliced into the LED harness Orange wires.

*The last page is a wire diagram of how the LED harness splices into the car's original harness.*



*Insert wire onto T-Tap*



*Crimp with pliers*



*Plug connector into T-Tap*

To keep the wires neatly tucked and in line, take the spliced sections and fold them over to one side and tape them in place. This will allow you to place the wiring into loom or have the ability to wrap the LED harness wiring tightly away.

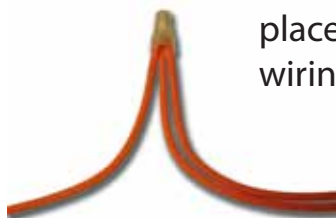

*Wires spliced together.*



*Fold wires over to a side.*



*Wrap with tape to hold in place.*

## LED PANEL MOUNTING INSTALLATION

The LED panel uses two mounting spots to sit securely on the housing. Test fit the LED panel. Each LED panel is labeled Drive or Passenger side on the backside. Plug the harness into the panel and test brake light, turn signal, and running light functions.

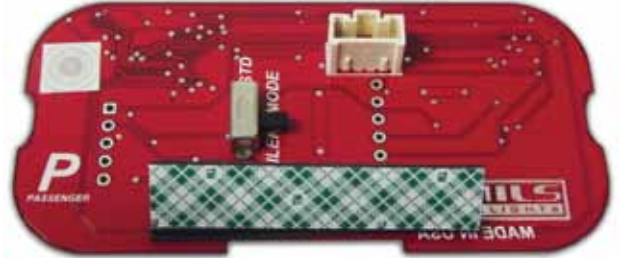

*Passenger Side LED Panel Shown.*

Once the LED panels test out fine use silicone or something similar to adhere and place some on the small rounded ledge. Remove the protective layer from the double sided tape and fit the LED panel into place.

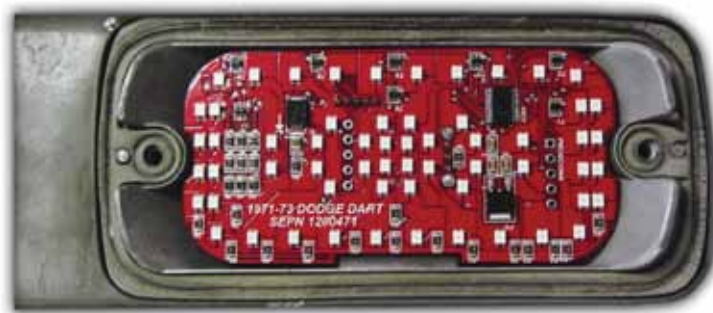

Re-install the housing and lens and test all light operations one last time.

ORIGINAL  
REAR BODY  
HARNESS

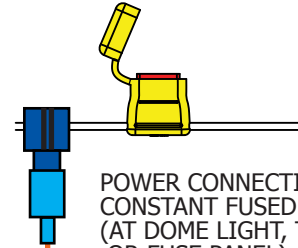

POWER CONNECTION  
CONSTANT FUSED POWER SOURCE.  
(AT DOME LIGHT, TRUNK LIGHT  
OR FUSE PANEL)

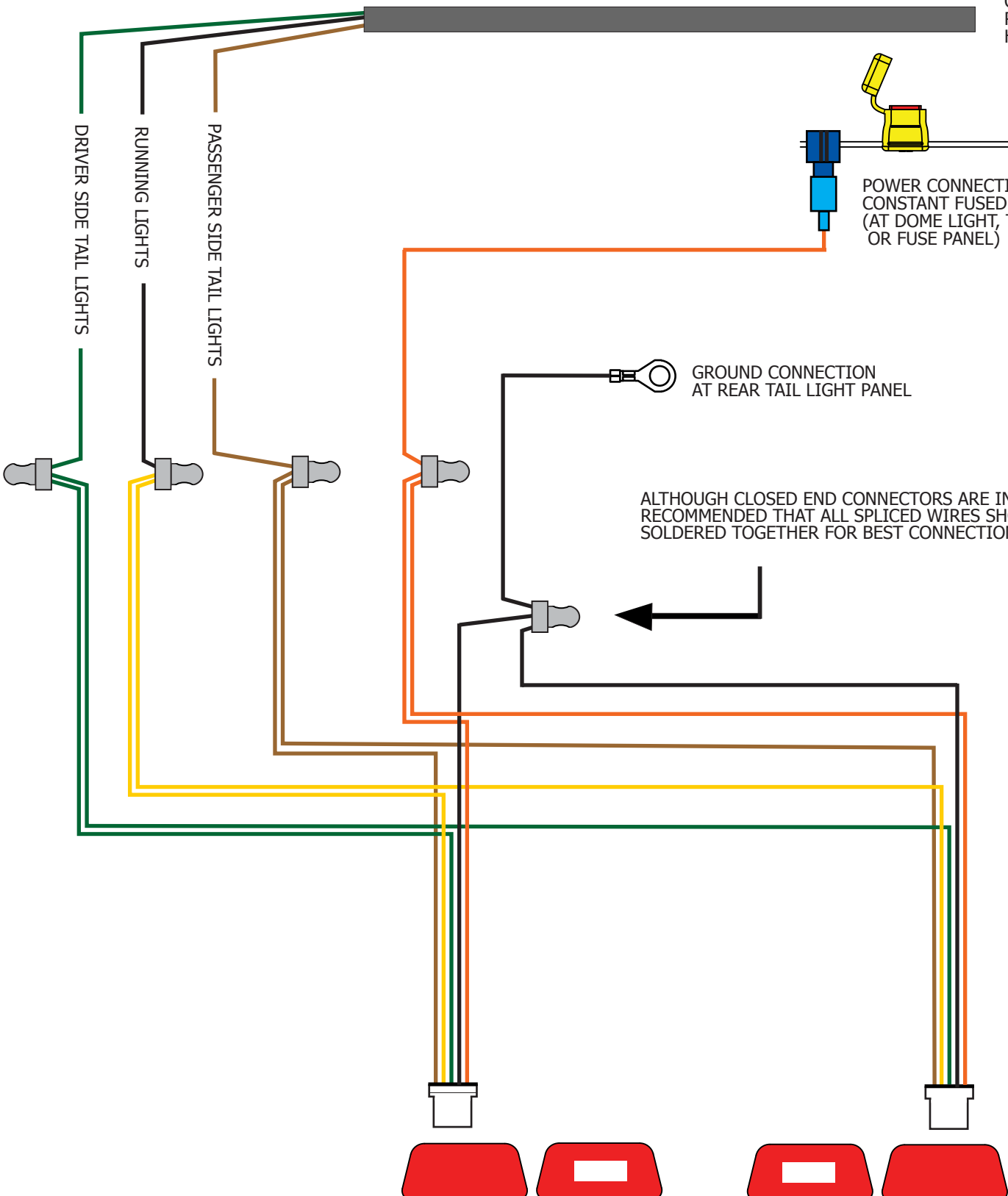

GROUND CONNECTION  
AT REAR TAIL LIGHT PANEL

ALTHOUGH CLOSED END CONNECTORS ARE INCLUDED, IT IS  
RECOMMENDED THAT ALL SPLICED WIRES SHOULD BE  
SOLDERED TOGETHER FOR BEST CONNECTION RELIABILITY.

DRIVER SIDE  
TAIL LIGHT HOUSING

PASSENGER SIDE  
TAIL LIGHT HOUSING